

Patent Drawings - Holiday Edition

NEWSLETTER Volume 4 + December 2012

What happens when you look at the holidays through the lens of a patent draftsman? We drank a lot of eggnog, did a little digging and came up with a bunch of interesting drawings. We were intrigued by sleighs and decided to present you with various sleigh drawings, past and present and some insight as to how they were created.

Patent drawings in the early days were done using graphite pencils on various types of paper. Velum (made from plasticized cotton); Mylar (a strong polyester film); Bristol board (an uncoated, machine-finished paperboard, named after the city of Bristol in the southwest of England) were the most commonly used. After graphite pencils, black ink was used to make patent drawings and in some rare cases still is today. A ruling pen was used to apply the ink. It is a drawing instrument which contains ink in a slot between two flexible metal jaws, which are tapered to a point. The line width can be adjusted by an adjustment screw connecting the jaws. For early draftsmen, these were often considered as instruments of torture, tricky to use and often lead to splotches of unwanted ink on nearly completed patent drawing.

After ruling pens came technical pens which were much easier to use.

Rideograph pens use a capillary cartridge to refill ink while isograph pens use a refillable ink reservoir. Besides ink & paper, many devices were used to make drawings. Some of these were rulers or straight edges for straight lines; triangle templates for angles; irregular curve templates or French curve templates; compasses and protractors and ellipse templates.

Making a mistake or making changes to drawings was no easy task to deal with in the early days. Erasers and blades were used to scrape off the top layer of paper containing the ink markings. You could only do that so many times before you had a hole through your drawing and had to start over.

Today most drawings are done on computer. Some of the programs used are Adobe Illustrator, CorelDRAW, Microsoft Office (Visio) and a number of CADD (Computer Aided Design & Drafting) programs.

But even before the United States Patent & Trademark Office opened in 1790 there are many drawings of inventions and sketches such as this detailed drawing by Giuseppe Arcimboldo.

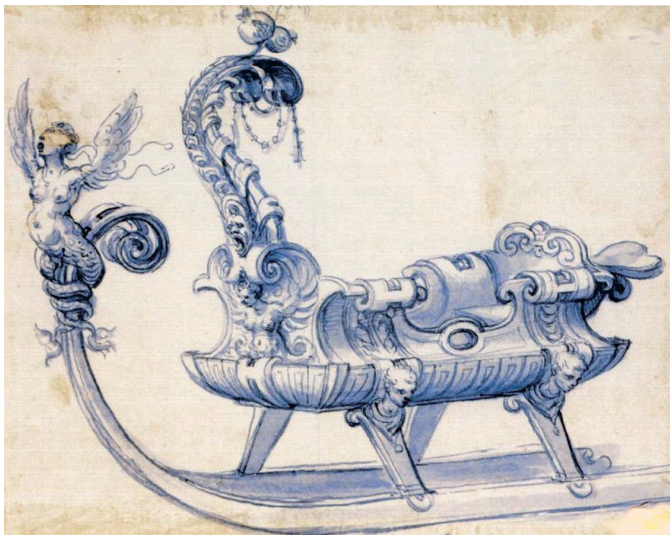

Giuseppe Arcimboldo - Italian, 1570s
Sketch for a sleigh
Pen, blue wash on white paper

Much time was committed to include all the detail shown in this sketch, making it a work of art.

IN NEXT MONTHS
FEATURE

When to file
photographs
In lieu of
patent drawings

Printable Newsletter

The mid to late 1890s saw many improvements to sleigh technology; making them safer, faster, smoother to ride, more durable and cheaper to manufacture.

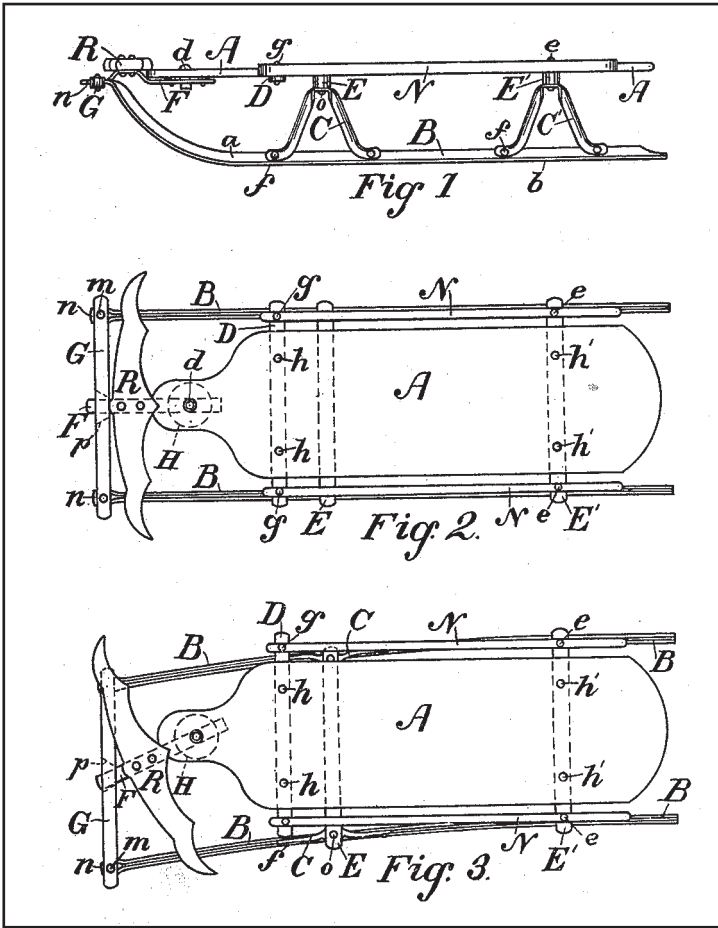

Samuel Leeds Allen
 (May 5, 1841-March 28, 1918)
 invented the first steerable runner sled.
 The best-selling and most famous American sled for over one hundred years. Its unique feature was the ability to steer the sled away from obstacles, making it a suitable choice for the safety conscious.

Patent # 408,681
 Issued August 13, 1889

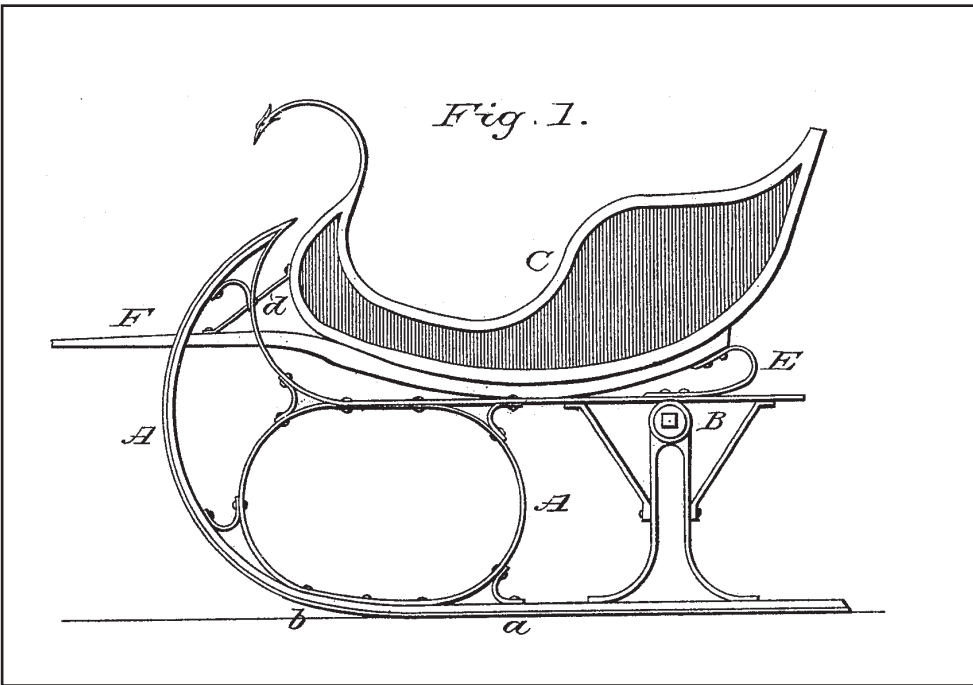

Patent # 245,597
 Issued August 9, 1881

Inventor John Zbornik explains "The object of my invention is to furnish an easy-riding and easy-running sleigh, with the runners so arranged that they will conform to the unevenness of the roads without strain upon the runners or box, and will run without jolting or bumping over the roughest roads. In my sleigh the runners, upon meeting with an obstruction or depression in the road, rise or descend, as the case may be, without communicating the jerking or pitching to the body of the sleigh, which by means of the tongue or thills is kept in nearly level position, while the springs convert the up-and-down movements into an easy undulation, making it much more comfortable and easy riding for the occupants and also easier work for the horses."

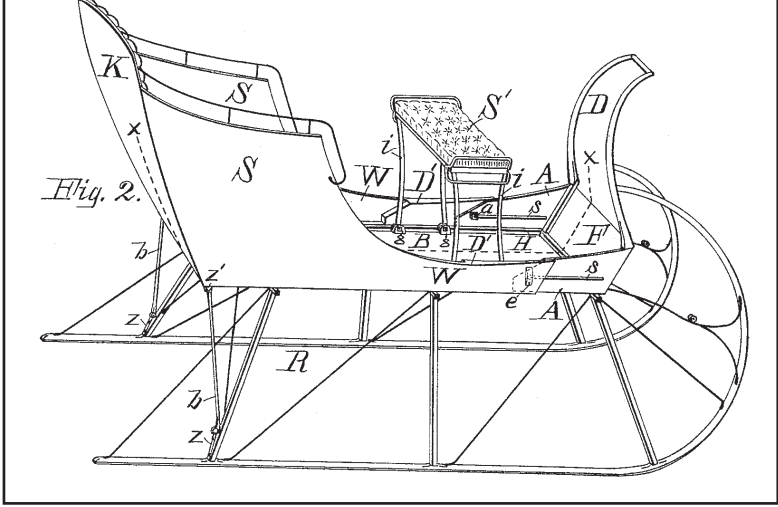

Inventor W. D. Rumsey explains, "This invention relates to certain improvements in sleighs, the object being to construct a cheap and durable sleigh which may be readily changed from a single to a double seated sleigh, or vice versa."

Patent # 407,120
 Issued July 16, 1889

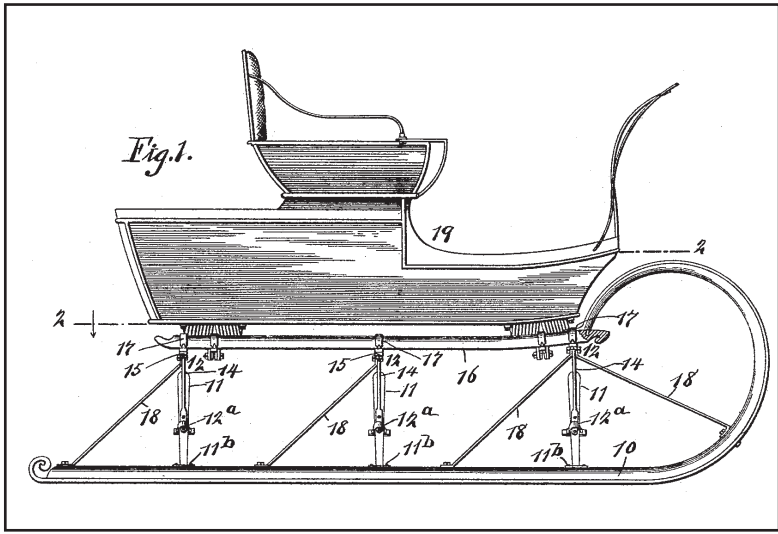

Inventor W.N. Snow explains: "the object of my invention is to improve the running gear of the side-bar spring sleighs, to the end that said running gear may be cheaply made, may be exceedingly strong, and will carry the body of the sleigh in a safe and correct manner."

"The running gear described above is exceedingly strong, and as it is composed of comparatively few parts, it is cheap and can be easily made."

Patent # 495,845
 Issued April 18, 1893

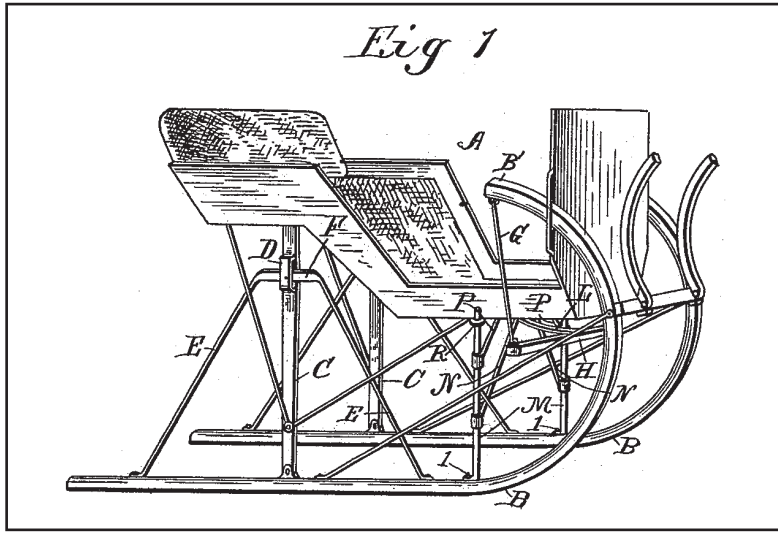

Inventor H. B. Ellsworth explains, "My invention has reference to improvement in sleighs, and more especially pertains to certain devices for the permitting of both a longitudinal and lateral oscillation to the sleigh body, to obviate the unpleasant effects of the jar of opposing inequalities or obstacles, on the ground."

Patent # 510,123
 Issued December 5, 1893

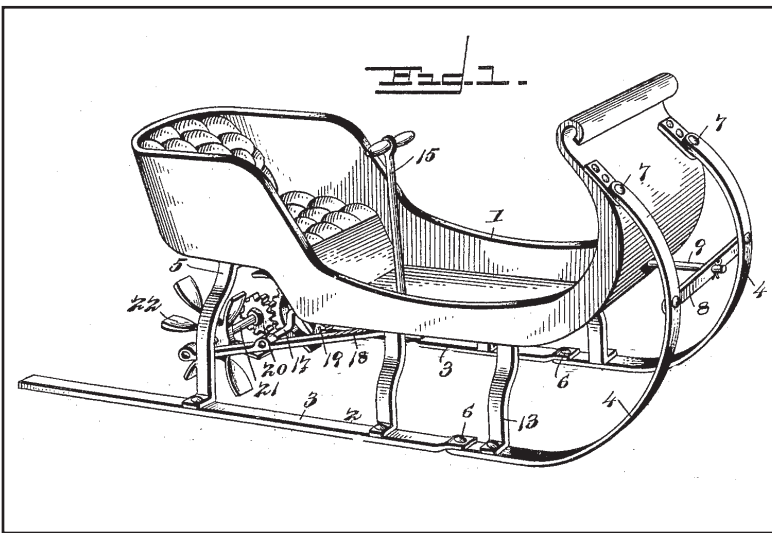

Inventor A.W. Koski explains, "The construction of that class of sleighs which are adapted to be propelled by the occupant and to provide one which may be effectually guided by the feet of the operator." "It will be seen that the sleigh may be readily guided by the feet of the operator, and his hands are left free to be employed for propelling the sleigh."

Patent # 581,595
 Issued April 27, 1897

Jumping forward we have the following ornamental sleigh patent drawing samples:

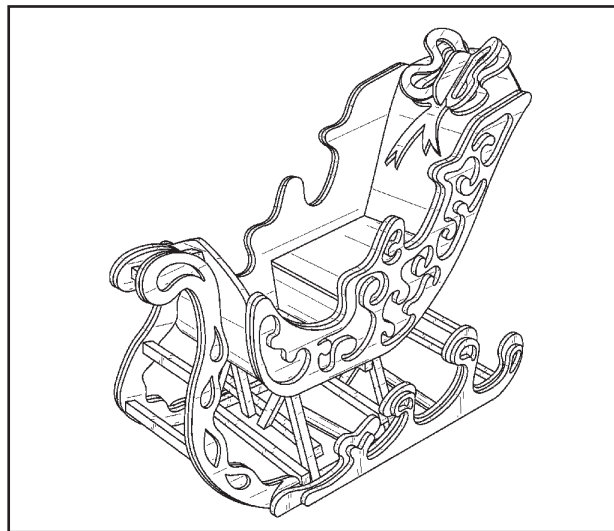
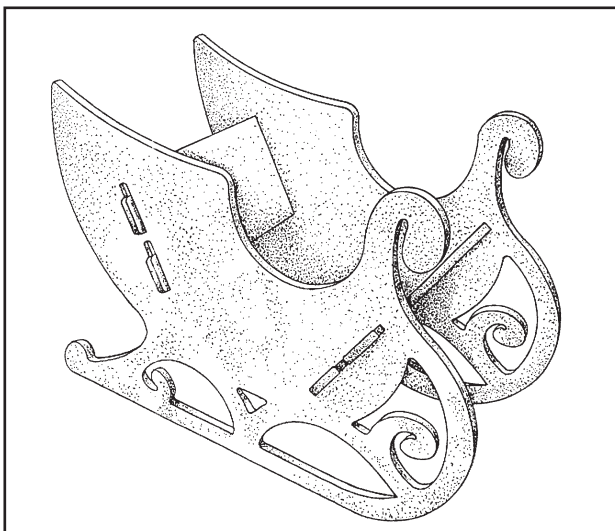

Patent # Des. 389,089 - Issued January 13, 1998
 Inventors: Sudhir K Lal & Kulwant S Hundal

Patent # D628,119 S - Issued November 30, 2010
 Inventor Donald Sandberg

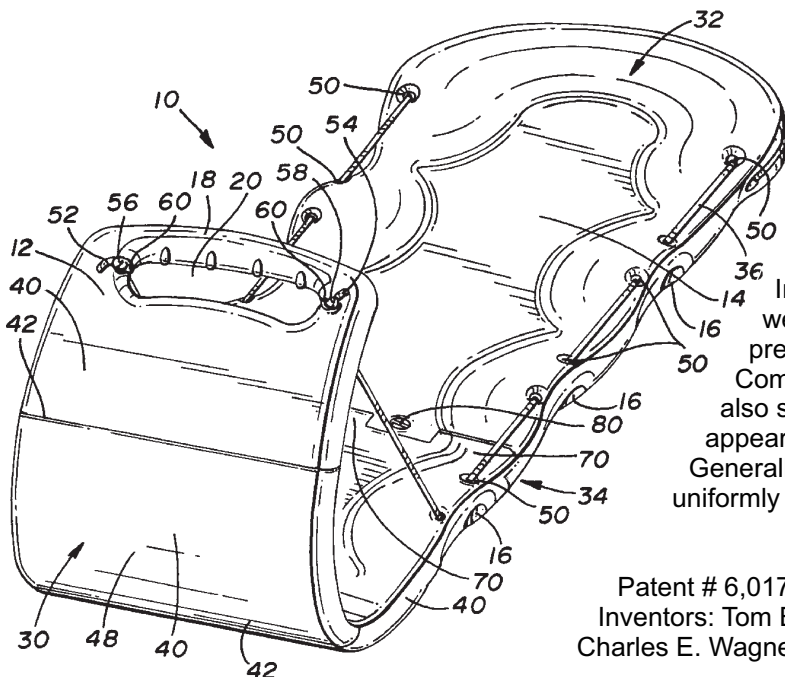

The unique feature here is "the toboggan may be folded into a compact form by removing the bolts and disconnecting the connector. The sections may then be folded over on top of each other."

In drawings past, often letter references were used, whereas today, the USPTO prefers that we use numerical references. Comparing this drawing to old drawings we also see much less shading, making it appear cleaner and less crowded. Generally computer generated drawings have uniformly thick, solid black lines.

Patent # 6,017,043 - Issued January 25, 2000
 Inventors: Tom B. Bennett; Greg Floyd; Kevin Rausch; Charles E. Wagner

Here are some interesting facts about holiday-themed inventions:

In the 1930's, the Addis Brush Company created the first artificial-brush trees, using the same machinery that made their toilet brushes! The Addis 'Silver Pine' tree was patented in 1950.

Candy canes first appeared around 1670 when a cathedral choirmaster handed out the all-white confections to children to keep them occupied during Christmas mass.

People first began putting lights on their Christmas trees in the 17th century by attaching small candles to the branches using wax or pins. The first electric Christmas lights were developed by Edward Johnson, an associate of Thomas Edison's, in 1882. Johnson hand-wired 80 red, white and blue lights and wrapped them around a rotating evergreen.

Around 1610, tinsel was invented in Germany made from genuine silver. Machines were invented that shredded silver into thin tinsel-sized strips.

At NBG we love eggnog, so here's the eggnog story:

Eggnog, or egg nog, its origins, and the ingredients used to make the original eggnog drink are debated. Eggnog may have originated in England; or it may have simply developed from posset, a medieval European beverage made with hot milk. The "nog" part of its name may stem from the word "noggin", a Middle English term used to describe a small, carved wooden mug used to serve alcohol.

Another story is that the term derived from "egg and grog", a common Colonial term used for the drink made with rum. Eventually that term was shortened to "egg'n'grog", then "eggnog".

In Britain, the drink was popular mainly among the aristocracy. Those who could get milk and eggs mixed it with brandy, Madeira or sherry to make a drink similar to modern alcoholic egg nog.

The drink crossed the Atlantic to the English colonies during the 18th century. Since brandy and wine were heavily taxed, rum from the Triangular Trade with the Caribbean was a cost-effective substitute. The inexpensive liquor, coupled with plentiful farm and dairy products, helped the drink become very popular in America. When the supply of rum to the newly-founded United States was reduced as a consequence of the American Revolutionary War, Americans turned to domestic whiskey, and eventually bourbon in particular, as a substitute.

The Eggnog Riot occurred at the United States Military Academy on 24–25 December 1826. Whiskey was smuggled into the barracks to make eggnog for a Christmas Day party. The incident resulted in the court-martialing of twenty cadets and one enlisted soldier.

I wish you and your families the happiest of holidays.

Bernadette